

SL Schienenlänge 355,6 ± 3,3

AL Auszugslänge 355,6 ± 3,3

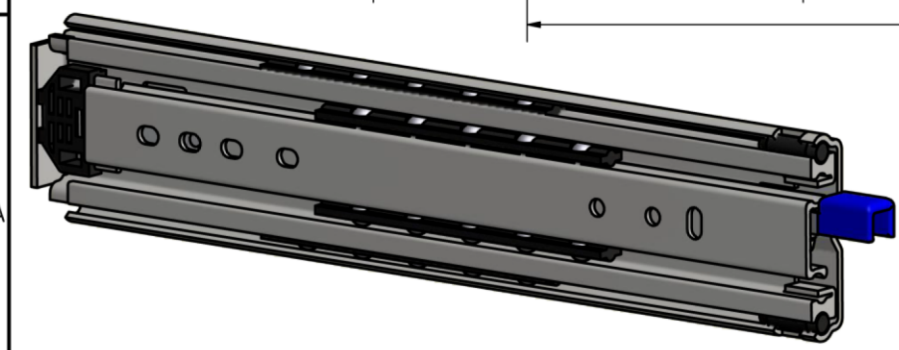
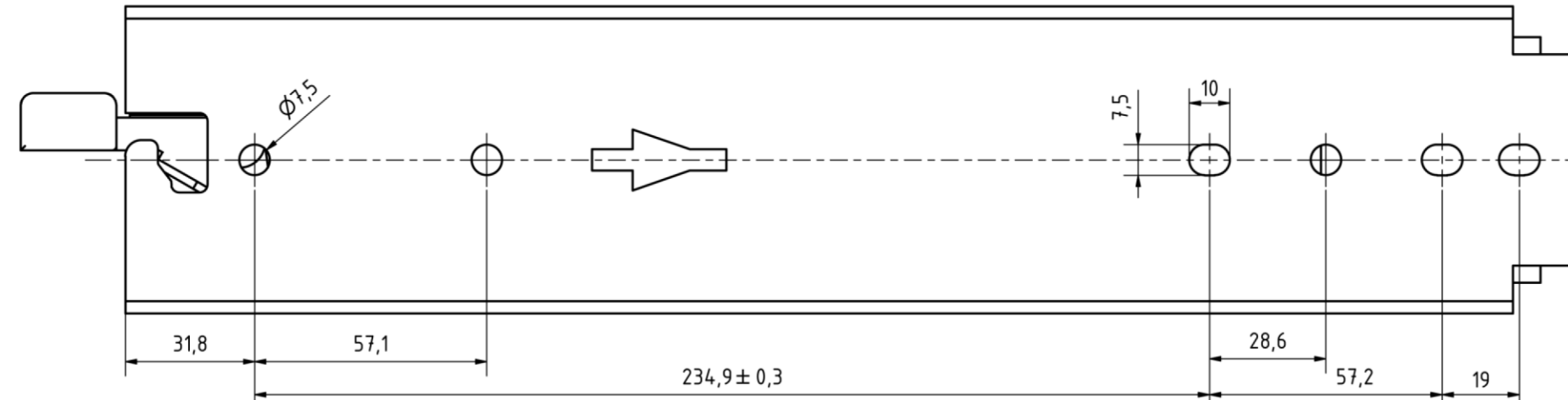
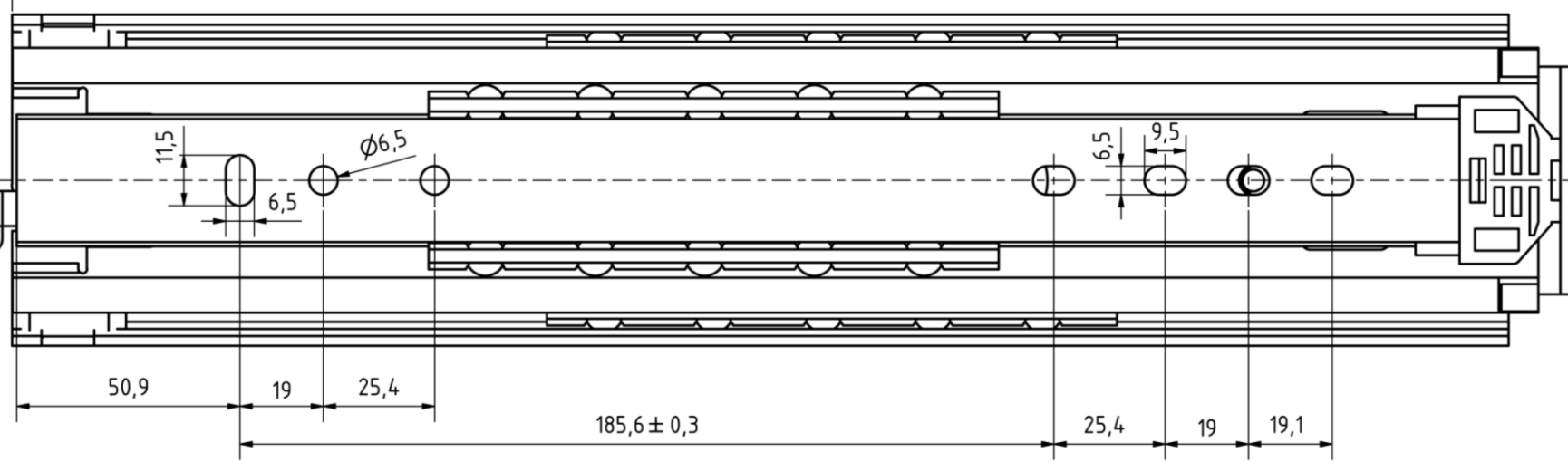
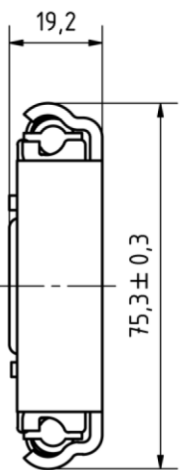

Werkstückkanten DIN Allgemeintoleranzen ISO 2768 - mK Tolerierung DIN 7167		Oberfläche DIN ISO 1302		Maßstab:	Revision
				Werkstoff:	
				Schwerlastauszug mit Verriegelung	
		MULTISLIDES Holger Stoof info@teleskopschienen24.de		Zeichnungsnummer: 2257619 - 355 lock	
				1 A3	
Zust.	Änderungen	Datum	Name		