

6 5 4 3 2 1

D

D

C

C

B

B

A

A

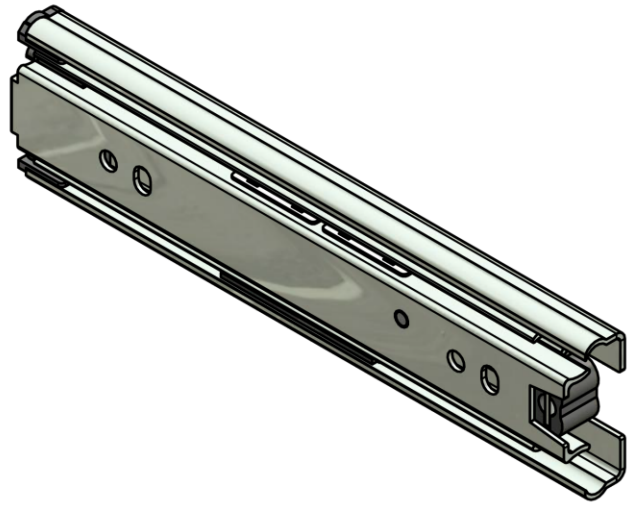
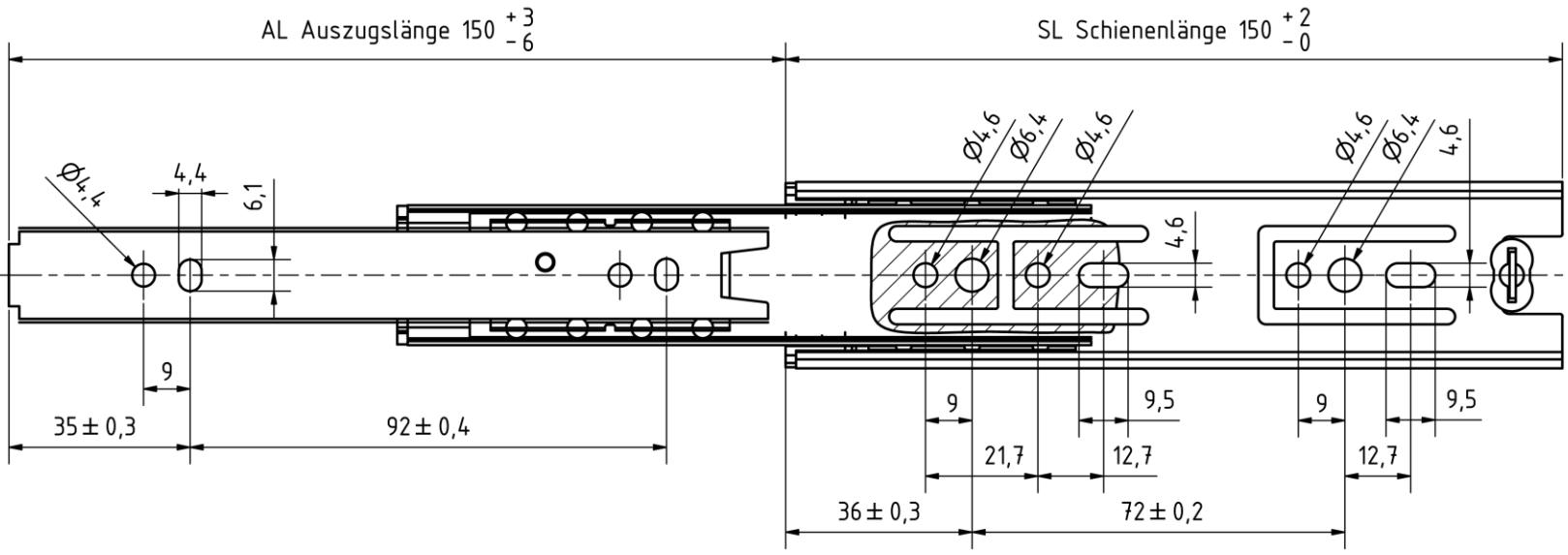
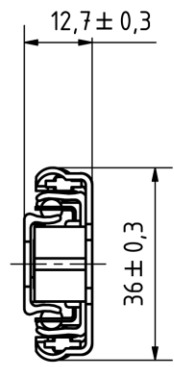

Werkstückkanten DIN Allgemeintoleranzen ISO 2768 - mK Tolerierung DIN 7167		Oberfläche DIN ISO 1302		Maßstab:	Revision
				Werkstoff:	
				Vollauszug	
		MULTISLIDES Holger Stooß info@teleskopschienen24.de		Zeichnungsnummer: TSNEW 353613 - 150mm	1 A3
Zust.	Änderungen	Datum	Name		

6 5 4 3 2 1